

Guide to charging Sealed Lead Acid batteries

Sealed lead acid batteries are widely used, but charging them can be a complex process:

Charging Sealed Lead Acid (BULLSPower) batteries does not seem a particularly difficult process, but the hard part in charging an BULLSPower battery is maximising the battery life. Simple constant current / constant voltage chargers will do the job for a while, but the battery life expectancy quoted by the manufacturer will be greatly reduced by using non-intelligent chargers like this. Maximising the life of your BULLSPower battery by using an intelligent charger is not only cost effective, it is also better for the environment.

Before looking at the different charging techniques it is important to understand the battery chemistry and what happens during normal charge and discharge cycles.

Typically the positive plates in an BULLSPower battery are made from lead dioxide and the negative plates from a sponge lead. The electrolyte is usually sulphuric acid mixed with a gelling agent and is largely absorbed and held by insulating separators between the plates, see Figure 1.

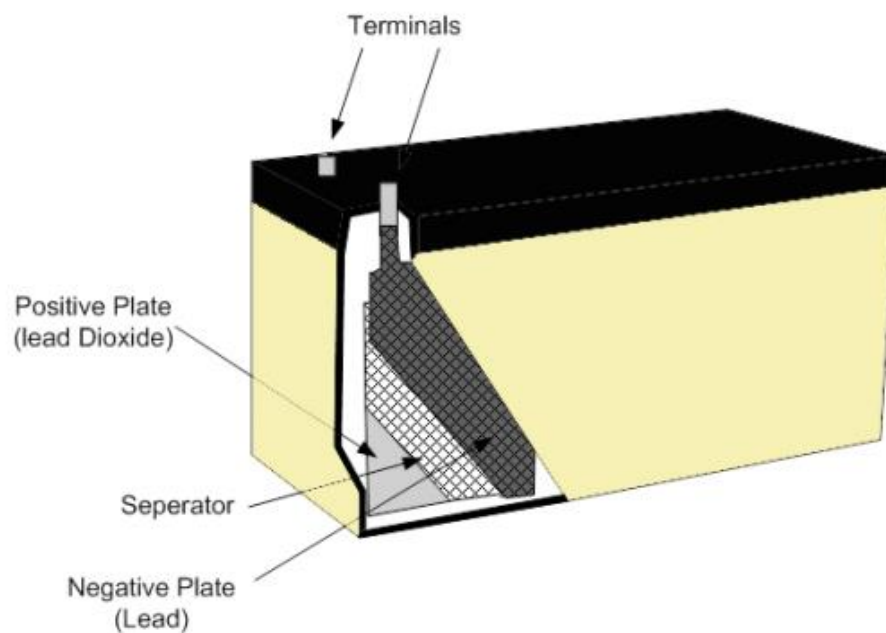

When an BULLSPower battery is being discharged; the lead (Pb) on the negative plate and the lead dioxide (PbO₂) on the positive plate are converted to lead sulphate (PbSO₄). At the same time the sulphuric acid (H₂SO₄) is converted to water (H₂O).

In a normal charge, the chemical reaction is reversed. The lead sulphate and water are electrochemically converted to lead, lead dioxide and sulphuric acid. During a full charge cycle

any gasses produced need to be re-combined in a so called 'oxygen cycle'. Oxygen is generated at the positive plates during the latter stages of the charge cycle, this reacts with and partially discharges in the sponge lead of the negative plates. As charging continues, the oxygen produced also re-combines with the hydrogen being produced on the negative plate forming water. With correct and accurate cell voltage control all gasses produced during the charge cycle will be re-combined completely into the negative plates and returned to water in the electrolyte.

If an BULLSPower battery is over-charged, the excess cell voltage will result in the conversion of electrolyte into large amounts of hydrogen and oxygen gasses which cannot be recombined by the normal processes. A pressure-release valve will open and vent the excess gas, resulting in the loss of electrolyte and a loss of capacity.

If the battery is undercharged; the low cell voltage will cause the charge current to diminish to zero well before full capacity is reached. This will allow some of the lead sulphate produced during discharge to remain on the plates, where it will crystallise, which also causes a permanent loss of capacity.

It is also important to remember that BULLSPower batteries have a self discharge rate of approximately 5% per month. This is less than most other forms of rechargeable batteries, but has to be considered. Manufacturers recommend recharging when the battery reaches about 70% of its capacity (approximately 2.1 volts per cell). They use this to calculate the maximum life of the battery, but this is very difficult to implement in a real world application

So let us look at different charging techniques: -

Constant Voltage Charging: this method is the most commonly used for BULLSPower batteries as the individual cells tend to share the voltage and equalize the charge between them. It is important to limit the initial charging current to prevent damage to the battery. However, with a single fixed voltage, it is impossible to properly balance the requirements of a fast charge cycle against the danger of overcharge.

Constant Current Charging: this method can be used for a single 2V cell but is not recommended for charging a number of series connected cells, a battery, at the same time. This is because some cells will reach full charge before others and it is very difficult to determine when the battery has reached a fully charged state. If the charge is continued at the same rate, for any extended period of time, severe overcharge may occur to some cells, resulting in damage to the battery.

Taper Current Charging: this method is not really recommended for charging BULLSPower batteries as it can often shorten battery service life due to poor control of the final fully charged voltage. However, because of the simplicity of the circuit and subsequent low cost, taper current charging is often used to charge a number of series connected batteries that are subject to cyclic use. When using this method it is recommended that the charging time is either limited or that a charging cut-off circuit is incorporated to prevent overcharge.

Two Stage Constant Voltage Charging: this method is a recommended for charging BULLSPower

batteries in a short period of time and then maintaining them in a fully charged float (or standby) condition.

Each of the above has its advantages and disadvantages, but using a simple charger design may not be cost effective in the long term. Checking battery condition and replacing batteries with lost capacity is very costly and environmentally unfriendly. So designing a charger to maximise the life of the BULLSPower battery is very important.

Another important factor that has to be considered when charging an BULLSPower battery is temperature. As the temperature rises, electrochemical activity in a battery increases, so the charging voltage should be reduced to prevent overcharge. Conversely as temperature falls, the change voltage should be increased to avoid undercharge.

Using a combination of the constant current charging and two stage constant voltage charging techniques and also by monitoring the battery terminal voltage and temperature a multi-stage charge profile can be implemented to reduce stress on the battery while giving the shortest possible charge time.

Figure 2 shows the multi-stage charge profile used by the Silvertel Ag102 module, for a 6-cell battery that will achieve this. The upper trace shows the charge voltage and the lower trace shows the charge current.

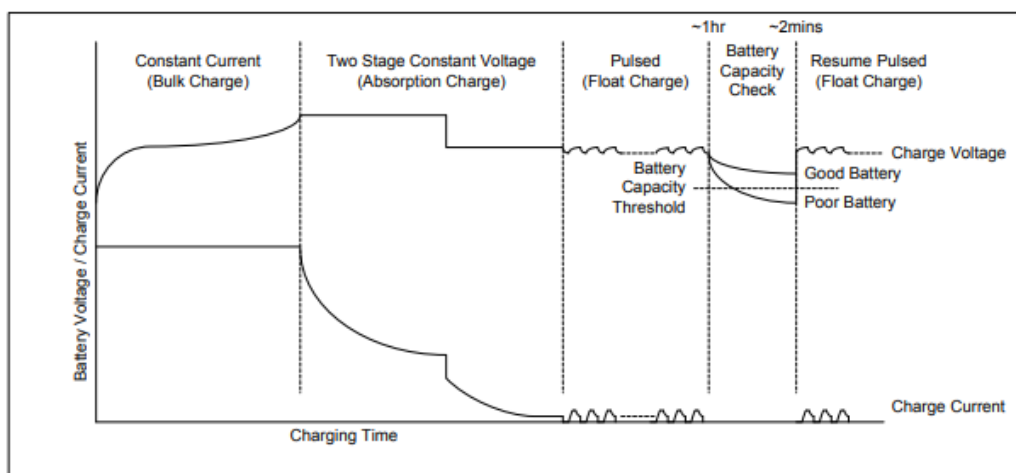

Figure 2: Ag102 Charge Profile

The first part of the multi-stage charge cycle is constant current mode “Bulk Charge”; Ag102 limits this to a maximum of 0.25C Amps (a quarter of the battery capacity), as required by BULLSPower batteries. For example, if the capacity of the BULLSPower battery being charged is 4Ah, then the constant current should be limited to 1 Amp. During this stage, the Ag102 monitors the battery terminal voltage until the terminal voltage reaches 14.4V (2.40V/cell).

Once the terminal voltage reaches 14.4V; the Ag102 charge cycle automatically moves on to the second stage “High Absorption Charge”. The Ag102 output changes from constant current to

constant voltage and now monitors the charge current. When the charge current drops to 0.05C Amps, which is 0.2 Amps for a 4Ah battery, the battery will have recovered approximately 70-80% of its charge. At this point the Ag102 output voltage reduces to 13.65V (2.275V/cell) - this is the "Low Absorption Charge". The remaining 20-30% of the charge is carried out at this lower voltage in order to prevent over-charge. Ag102 will stay in this mode until the battery is fully charged.

The final stage of the charge cycle is the "Float Charge". This can be done by accurately maintaining the low absorption voltage level, or as with the Ag102, by providing an intermittent float charge as shown in Figure 2. These methods ensure that the battery is not being over-charged, as over-charging will result in battery stress, reducing the battery life. During the intermittent float charge, Ag102 will periodically check battery capacity, and flag this information

All the above charge voltages are based on an ambient temperature of between 20°C to 25°C. For the best performance these voltages will need to be temperature compensated by approximately 4mV/°C/Cell (reduced at higher temperatures and increased at lower temperatures). Ag102 has the ability to provide temperature compensation via PTC thermistor input – the PTC thermistor connects to the battery, and the Ag102 automatically adjusts all charging voltages to compensate for temperature variances, thus always maintaining optimum charge performance for the BULLSPower battery – maximising battery life, and minimising charge times.

There are limits to the battery operating temperature and BULLSPower battery life is greatly reduced at higher ambient temperatures. For more information on this you will need to refer to the battery manufacturer's datasheet.